



## hanit® SUTTON 2 BENCH

### Modern shape, traditional charm

The distinctive sledge-runner shape of the legs makes the Sutton a real eye-catcher. It's an obviously modern design but it doesn't lose touch with traditional charm. The Sutton always looks good, even as part of a seating group and comes in three different sizes.

#### Material:

hanit® Recycled Plastic

#### Surface:

Structured, grained

#### Dimensions (W x D x H):

200 x 60 x 80 cm

#### Seat height:

45 cm

#### Weight:

85 kg

#### Slats:

Premium type

5 bench boards 200 x 10 x 4.7 cm

Internal reinforcement

#### Advantages:

Durable and dimensionally stable

Never paint, varnish or grind again

No risk of injury from splinters

No annoying mothballing in winter (weatherproof)

Fast drying, no water absorption

Resistant to vandalism

#### Optional:

Ground anchor type 1

Arm rest



 Brown





TECHNICAL DRAWING

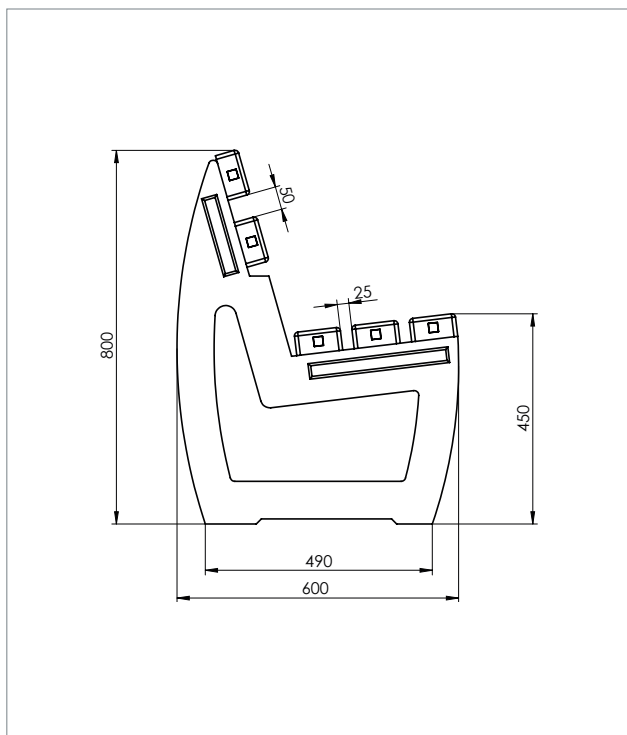

TECHNICAL DATA

Sutton 2 bench, width: 200 cm

Colour	Dimensions W x D x H (approx. cm)	Weight (approx. kg)	Order No
■ Brown	200 x 60 x 80	85.0	BAA 10 200

Benches and tables are delivered as a kit. Assembly instruction and materials are included.



FURTHER DOCUMENTS PLEASE SEE WWW.HANIT.DE

- » Assembly Instruction
- » Tender Specifications
- » Tests and Certificates
- » General Material Remarks

