



# hanit® SUTTON 3 BENCH

Modern shape, traditional charm

The distinctive sledge-runner shape of the legs makes the Sutton a real eye-catcher. It's an obviously modern design but it doesn't lose touch with traditional charm. The Sutton always looks good, even as part of a seating group and comes in three different sizes.

**Material:**

hanit® Recycled Plastic

**Surface:**

Structured, grained

**Dimensions (W x D x H):**

240 x 60 x 80 cm

**Seat height:**

45 cm

**Weight:**

150 kg

**Slats:**

Classic type

5 bench boards 240 x 12 x 6 cm

Milled reinforcement

**Advantages:**

Durable and dimensionally stable

Never paint, varnish or grind again

No risk of injury from splinters

No annoying mothballing in winter (weatherproof)

Fast drying, no water absorption

Resistant to vandalism

**Optional:**

Ground anchor type 1

Arm rest



 Brown





**TECHNICAL DRAWING**

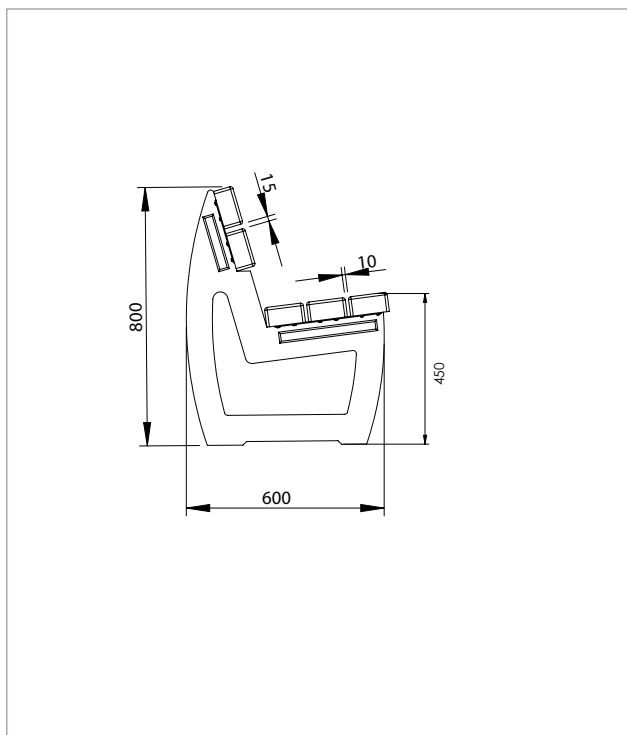

**TECHNICAL DATA**

**Sutton 3 bench, width: 240 cm**

Colour	Dimensions W x D x H (approx. cm)	Weight (approx. kg)	Order No
■ Brown	240 x 60 x 80	150.0	BML 12 240

Benches and tables are delivered as a kit. Assembly instruction and materials are included.

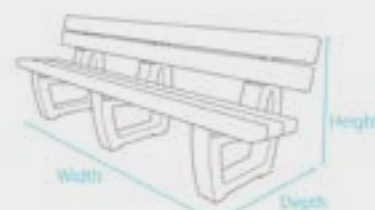

**FURTHER DOCUMENTS PLEASE SEE WWW.HANIT.DE**

- » Assembly Instruction
- » Tender Specifications
- » Tests and Certificates
- » General Material Remarks

